

POTAIN MD 120 A

UDŹWIG MAKSYMALNY 6 TON



Konfiguracja Wieży

KM 406 E 

$$H_{\square} = H_{\square} / \square + 0,3 \text{ m}$$

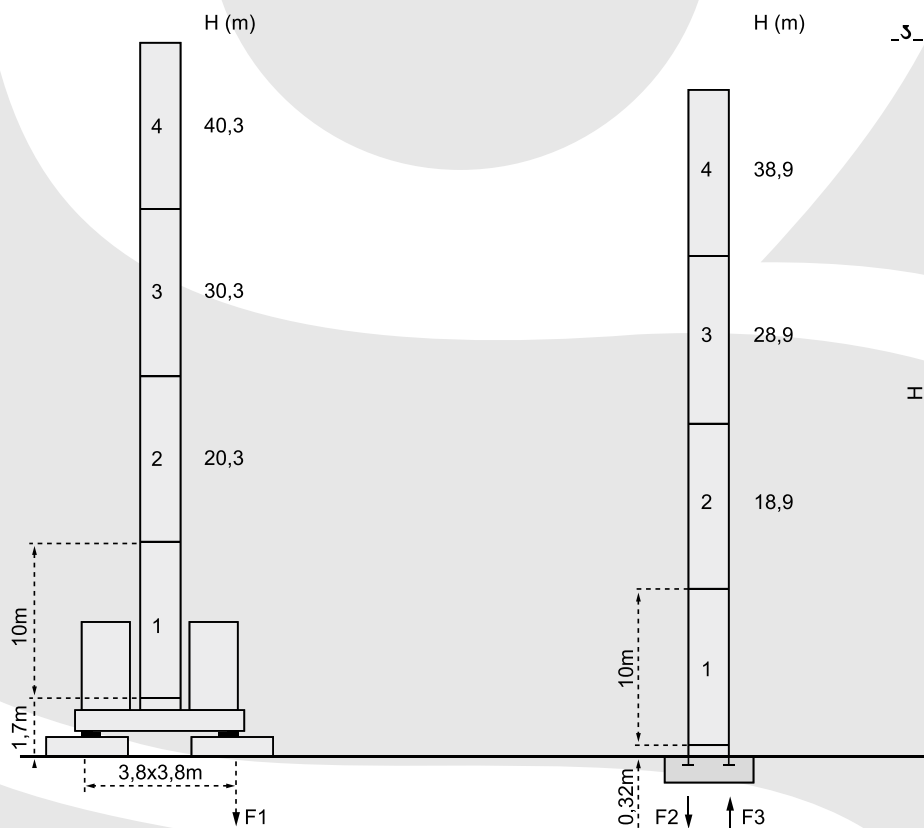

ZC 40 A

F1 ● 57t ■ 63t
35t

P 40 A

F2 ● 77t ■ 87t
F3 ● 50t ■ 63t
31t

ZC 40A

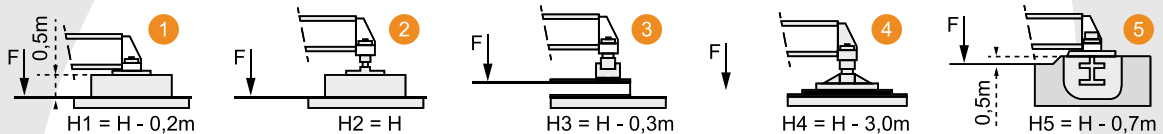

- W czasie pracy
- Poza pracą
-  Bez ładunku i balastu z maksymalnym wysięgnikiem i wysokością

POTAIN MD 120 A

UDŹWIG MAKSYMALNY 6 TON

HERKULES

Tabela udźwigów

	2,4 →	17,1	20	22	25	27	30,4	30,8	32	35	37	40	42	45	47	50	52	55	m
		6	4,97	4,44	3,81	3,46	3	3	2,86	2,56	2,38	2,16	2,02	1,85	1,74	1,6	1,51	1,4	t
									3	2,7	2,52	2,3	2,17	1,99	1,89	1,75	1,66	1,55	t
	2,4 →	19,3	22	25	27	30	32	34,4	34,9	37	40	42	45	47	50				m
		6	5,13	4,41	4,03	3,54	3,27	3	3	2,79	2,53	2,38	2,18	2,06	1,9				t
										37,1	40	42	45	47	50				m
										3	2,74	2,58	2,38	2,36	2,1				t
	2,4 →	19,4	22	25	27	30	32	34,6	35,2	37	40	42	45						m
		6	5,17	4,45	4,06	3,57	3,3	3	3	2,81	2,55	2,4	2,2						t
										37,3	40	42	45						m
										3	2,76	2,6	2,4						t
	2,4 →	19,8	22	25	27	30	32	35,1	35,6	37	40								m
		6	5,25	4,52	4,12	3,63	3,35	3	3	2,86	2,6								t
										37,7	40								m
										3	2,8								t
	2,4 →	19,8	22	25	27	30	32	35											m
		6	5,31	4,57	4,17	3,67	3,39	3,05											t
																			35 m
										3									t
	2,4 →	19,9	22	25	27	30													m
		6	5,31	4,57	4,17	3,67													t
																			30 m
										3									t
	2,4 →	20,1	22	25															m
		6	5,4	4,65															t
																			25 m
										3									t

/ Standardowy wózek 2/4 liny (przy użyciu odjąć 0,1T od)

Opcjonalny wózek 2 liny

		(kg)
55m	14,3m	17 250 (5x3450)
50m	13m	17 250 (5x3450)
45m	13m	16,050 (4x3450)+(1x2250)
40m	13m	13 800 (4x3450)
35m	13m	12 600 (3x3450)+(1x2250)
30m	13m	10 350 (3x3450)
25m	13m	9 150 (2x3450)+(1x2250)

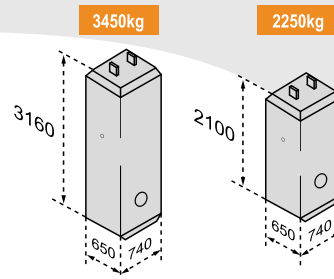

H (m)			H (m)			H (m)		
	55m	50-25m		55m	50-25m		55m	50-25m
40,3						56,5	108t	114t
						53,2	90t	96t
			49,8	78t	84t	49,8	78t	84t
			44,8	54t	60t	44,8	54t	60t
	65t	60t	39,8	48t	48t	39,8	48t	48t
30,3			34,8	48t	48t	34,8	48t	48t
	65t	60t	29,8	48t	48t	29,8	48t	48t
			24,8	48t	48t	24,8	48t	48t
20,3			19,8	48t	48t	19,8	48t	48t
	65t	60t						
ZC 40 A			S 40 A			S 41 A		

POTAIN MD 120 A

UDŹWIG MAKSYMALNY 6 TON



Inne konfiguracja Wieży

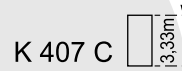
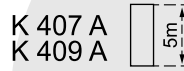
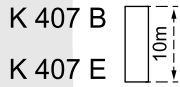

$$H_{\square} = H_{\square} / \square + 0,3m$$

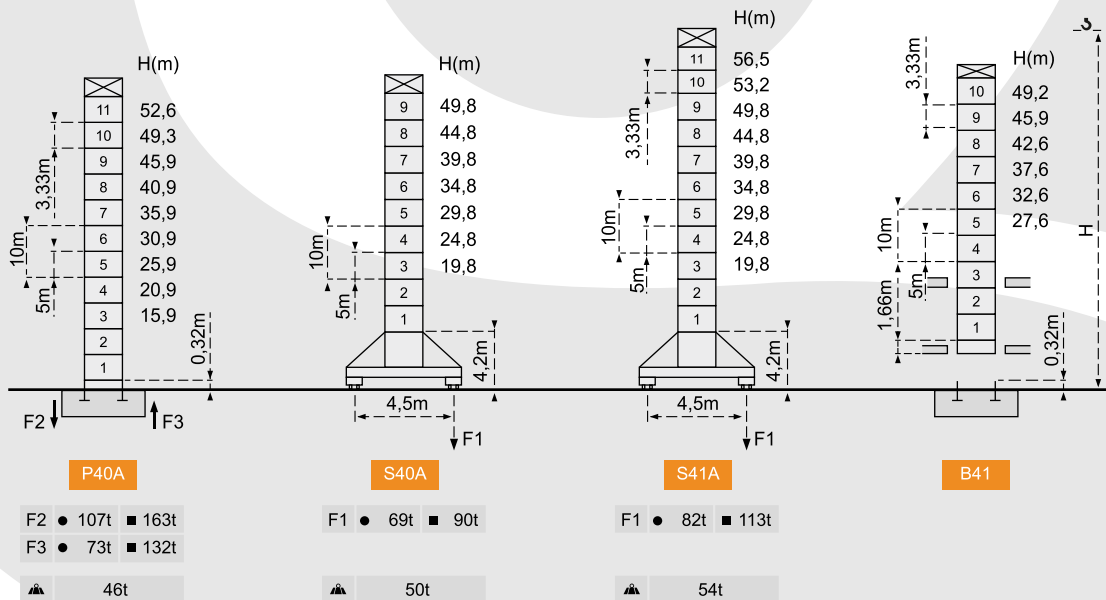

Teleskopowanie

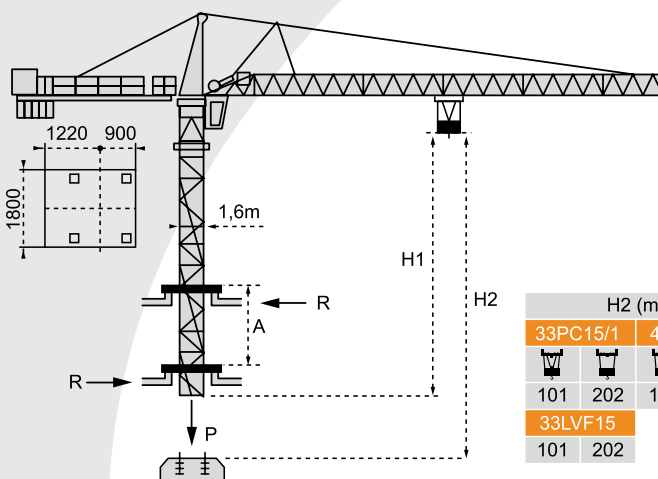

H2 (m)	
33PC15/1	45RCS15
101	202
118	236
33LVF15	
101	202

