

POTAIN MD 285

UDŹWIG MAKSYMALNY 12 TON

 **HERKULES**

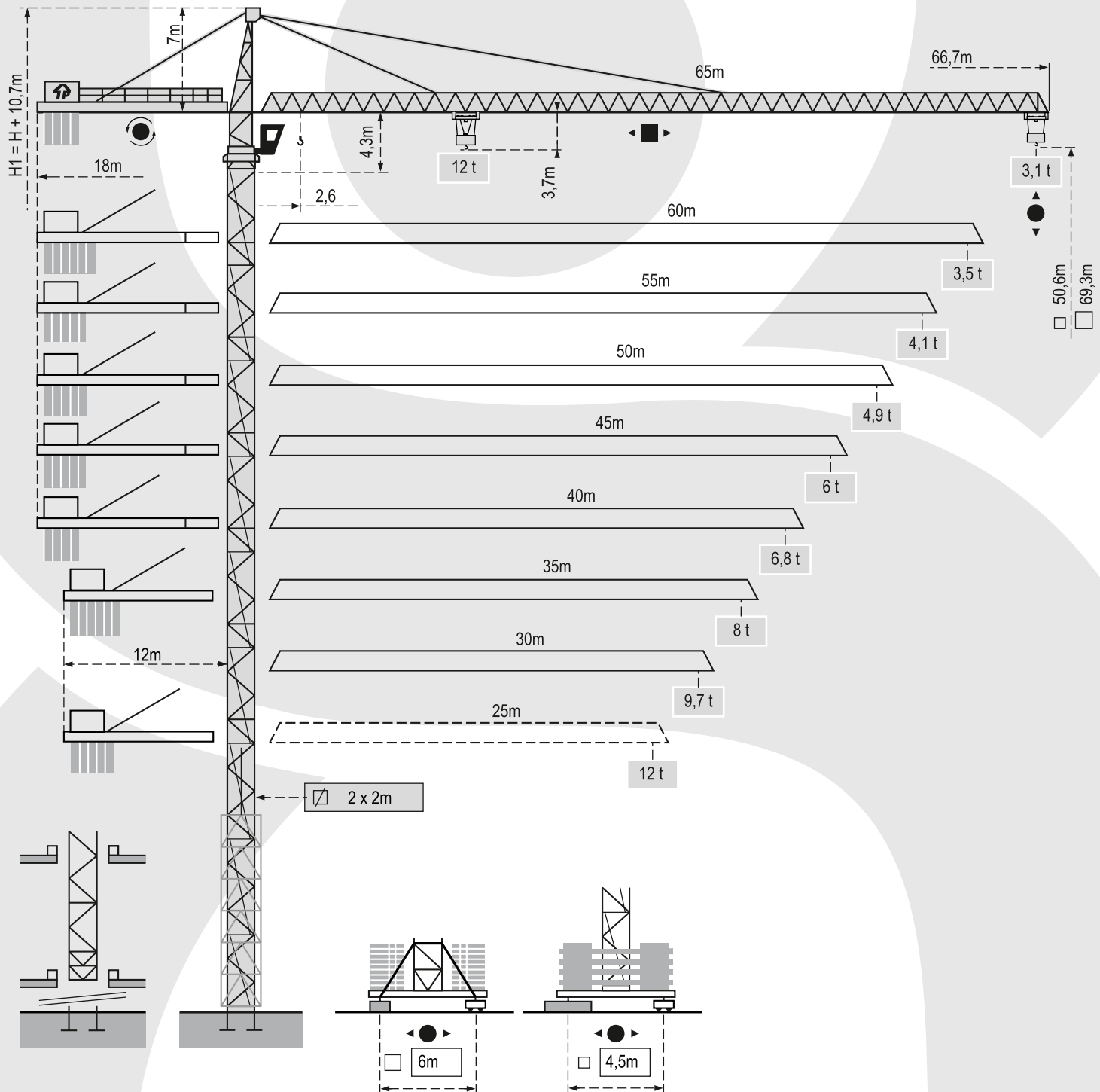

DANE TECHNICZNE:

UDŹWIG MAKSYMALNY: 12 TON

DŁUGOŚĆ WYSIĘGIKA: 65 M

UDŹWIG NA MAKSYMALNYM WYSIĘGIKU: 3,1 TONY

 **HERKULES**

www.herkules-polska.pl

POTAIN MD 285

UDŹWIG MAKSYMALNY 12 TON

 **HERKULES**

Konfiguracja Wieży

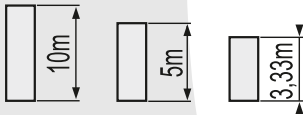

2m
MD 285 J12

$$H_{\text{total}} = H_{\text{tower}} + 0,7\text{m}$$

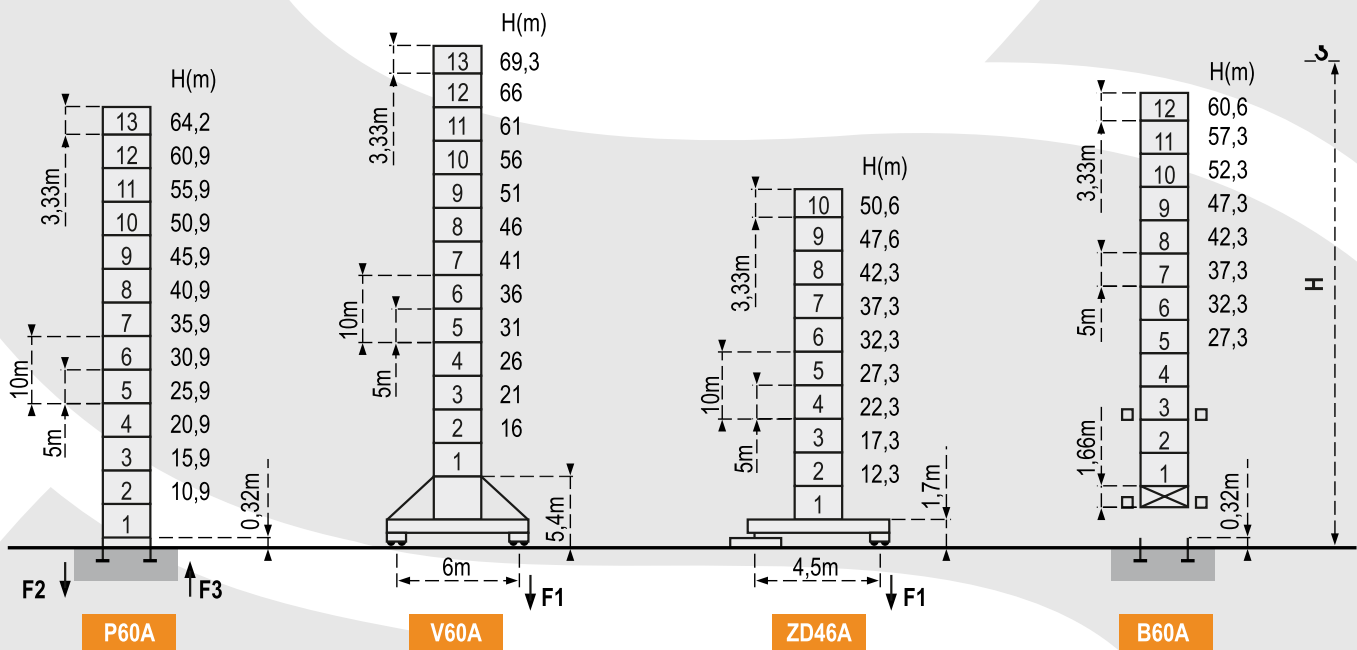

F2 ● 171 t ■ 215 t

F3 ● 115 t ■ 165 t

 77 t

F1 ● 111 t ■ 140 t

 89 t

F1 ● 96 t ■ 102 t

 80 t

● W czasie pracy

■ Poza pracą

 Bez ładunku i balastu z maksymalnym wysięgnikiem i wysokością

POTAIN MD 285

UDŹWIG MAKSYMALNY 12 TON



Tabela udźwignięć

65m		19,68	20	22	25	27	30	32	34,8	35,65	37	40	42	45	47	50	52	55	57	60	62	65	m
		12	11,77	10,52	9,03	8,23	7,23	6,67	6	6	5,72	5,18	4,87	4,45	4,2	3,86	3,66	3,38	3,21	2,98	2,84	2,65	t
		6t → 37,8m										5,61	5,3	4,88	4,63	4,3	4,1	3,82	3,66	3,43	3,29	3,1	t
60m		20,03	22	25	27	30	32	35,5	36,41	37	40	42	45	47	50	52	55	57	60	m			
		12	10,75	9,24	8,42	7,41	6,84	6	6	5,88	5,33	5,01	4,58	4,33	3,99	3,78	3,5	3,33	3,1	t			
		6t → 38,37m										5,71	5,39	4,97	4,72	4,38	4,17	3,9	3,73	3,5	t		
55m		20,82	22	25	27	30	32	35	36,96	37,87	40	42	45	47	50	52	55	m					
		12	11,25	9,68	8,83	7,77	7,18	6,42	6	6	5,6	5,27	4,82	4,56	4,2	3,99	3,7	t					
		6t → 39,95m										5,99	5,66	5,21	4,95	4,6	4,37	4,1	t				
50m		21,9	22	25	27	30	32	35	37	38,9	39,86	42	45	47	50	m							
		12	11,93	10,27	9,38	8,27	7,64	6,85	6,39	6	6	5,62	5,15	4,87	4,5	t							
		6t → 42,09m										6	5,55	5,27	4,9	t							
45m		23,37	25	27	30	32	35	37	41,54	42,57	45	m											
		12	11,09	10,13	8,94	8,28	7,42	6,93	6	6	5,6	t											
		6										t											
40m		24,84	25	27	30	32	35	37	40	m													
		12	11,91	10,89	9,62	8,91	8	7,48	6,8	t													
35m		24,84	25	27	30	32	35	m															
		12	11,91	10,89	9,62	8,91	8	t															
30m		24,84	25	27	30	m																	
		12	11,91	10,89	9,7	t																	
25m		25	m																				
		12	t																				

/ Standardowy wózek 2/4 liny
(przy użyciu odjąć 0,1T od)

Opcjonalny wózek 2 linowy

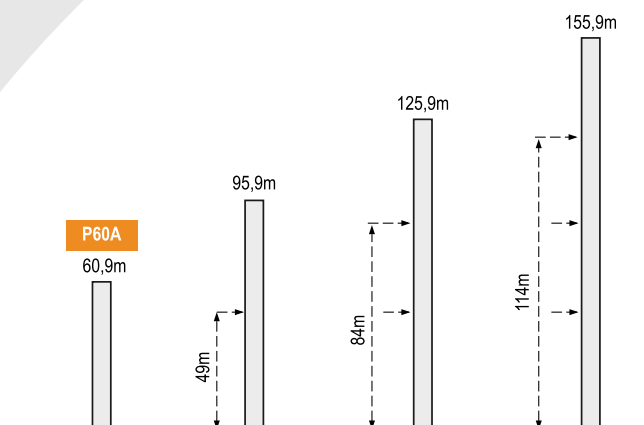









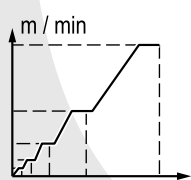

POTAIN MD 285

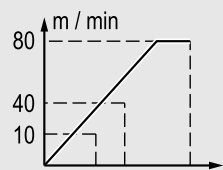
UDŹWIG MAKSYMALNY 12 TON

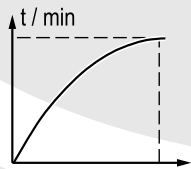
 **HERKULES**

Mechanizmy

					m/min	t		ch-PS hp	kW	
		55 RCS 30D		0 → 34	6	0 → 17	12	370m	55	40,5
				0 → 68	3	0 → 34	6	>370m*		
		70 RCS 30D		0 → 40	6	0 → 20	12	461	70	51
				0 → 80	3	0 → 40	6	>641*		
		6 D3 V4				10-40-80		6	4,4	
		RCV 185				0 → 0,8 tr/min rpm		2x8	2x5,2	
	ZD 46 A 	RT 443 A1 2V			15 - 30			4x5	4x3,7	
	V 60 A 	RT 544 A1 2V			13,5 - 27			4x7	4x5,2	
	 R ≥ 13m	TCV 649 ARC H ≤ 41 m			10 - 50			4x6,8	4x5	
							CEI 38 IEC 38	400V (+6%-10%) 50 Hz		
								55 RCS : 80 KVA		
								70 RCS : 105 KVA		
								*		